

# INTERNAL CENTER PANEL ABSORPTIVE DESIGN

## 20 to 25 dBA Noise Reduction

### FPC-FPCE OVERVIEW

Use for a medium to high degree of high frequency noise attenuation. FPC model is for intake service and the FPCE for exhaust service.

Typical Applications: Internal combustion engine intakes and exhaust, compressor intakes or fan intakes and discharges

### FEATURES

- Advanced acoustical design
- Heavy duty, all welded construction and long service life
- Easily installed in any position
- Prime coated exterior finish

### OPTIONS / ACCESSORIES

- Horizontal or vertical support arrangements
- Special paint
- Stainless steel construction
- Complete range of exhaust accessories

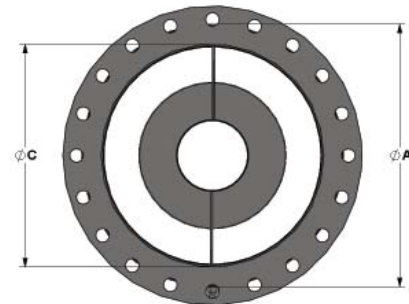
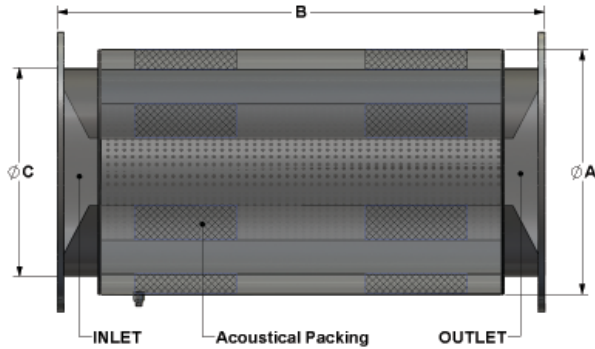
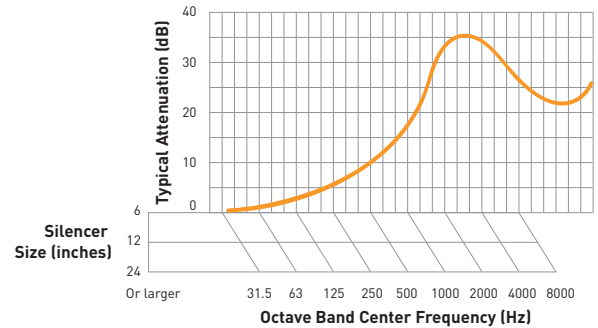

FPC - FPCE			
Size / $\phi C$	$\phi A$	B	Est Wt
14	18	35	200
16	20	39	240
18	22	44	300
20	24	48	360
22	26	52	430
24	28	56	590
26	30.375	60	700
28	32.5	64	800
30	35.375	68	900
32	37	72	1200
34	39.5	76	1330
36	42	80	1490

Note: Dimensions are in inches, weights are in pounds.