

16" INLET AND OUTLET FLANGES  
 1/2" PLATE, 23 1/2" O.D.  
 (16) 1 1/8" DIA. HOLES  
 ON 21 1/4" B.C. STRADDLE C.L.

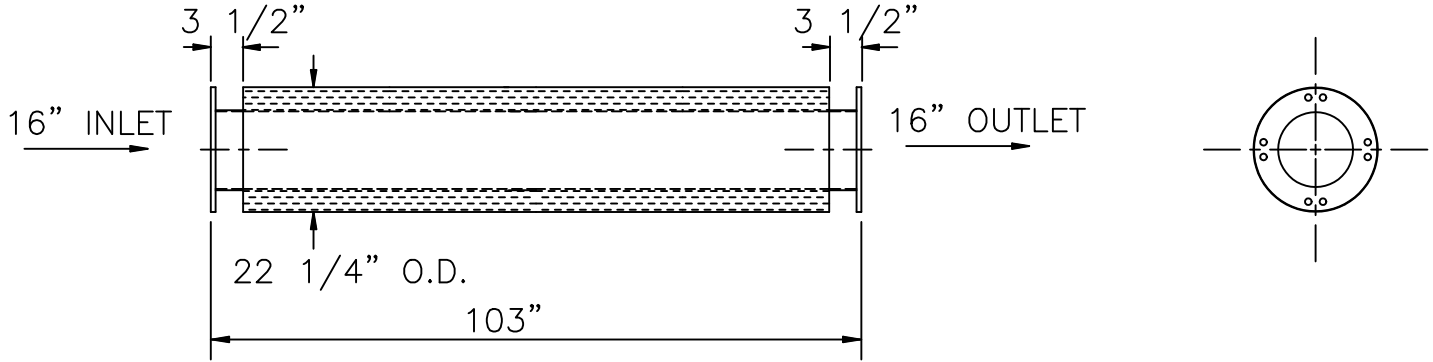

SERVICE : SUPPLEMENTAL EXHAUST SILENCER FOR RECIPROCATING ENGINE

OCTAVE BAND	63	125	250	500	1K	2K	4K	8K
INSERTION LOSS	4	10	18	27	33	30	23	22

SILENCER PRESSURE DROP :  
 \_\_\_ H2O AT \_\_\_\_\_ CFM, \_\_\_ °F

MATERIALS OF CONSTRUCTION :  
 SHELL : 1/8" CARBON STEEL  
 PERFO : 12 GA CARBON STEEL  
 PACKING : 6 LB/CU.FT. MINERAL WOOL

CERTIFICATION

CUSTOMER: \_\_\_\_\_  
 CUSTOMER P.O. NO.: \_\_\_\_\_  
 DATE: \_\_\_\_\_ BY: \_\_\_\_\_

EXTERNAL PAINT : HIGH TEMP BLACK

WEIGHT : 440 LBS.

MAXIM  
 SILENCERS, INC.

10635 BRIGHTON LANE  
 STAFFORD, TEXAS 77477  
 PHONE (832) 554-0980  
 FAX (832) 554-0990

16" FPE EXHAUST SILENCER

				DRAWN	TJW	2/20/00	ORDER NO.	DRAWING NO.	REV
				CHECKED				STD16FPE	
No.	REVISIONS	APPR.	APPROVED				SHEET	Sheet 1 of 1	