

M-36 to M-40 FLANGES

Flared, Machine Turbo, and Engine Flanges

Flared

Part Number	ID	OD	Length	V-Band Clamp
M-36-300	3	3.63	1.5	Call
M-36-350	3.5	4.25	1.5	Call
M-36-JD-400	3.9	4.41	3	35-JD-400
M-36-400	4	4.63	1.5	35-400
M-36-500	5	5.75	3	35-500
M-36-600	6	6.75	3	Call

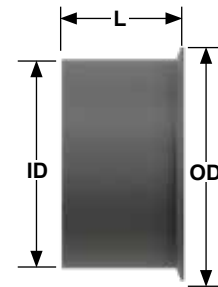

Machined Turbo (From 1018 Heavy Wall Tubing)

Part Number	Nom. Size	A	B	Clamp	Application
M-37-450	5	4.5	5	35-450	See Footnote†
M-37-550	6	5.3	6.2	35-550	DA 16V2000

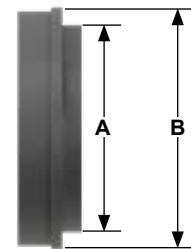

Standard Engine (Caterpillar, MTU, Cummins)

Part Number	Engine	Type	A (ID)	B (OD)	C (BC)	D (DIA)	Holes	E (THK)	WT
M-38-340	CAT	1	3	5.5	4.13	0.56	4	0.5	3
M-38-400	CAT	1	4.1	5.5	4.13	0.56	4	0.5	2
M-38-500	CAT	1	5.1	6.5	5	0.75	4	0.5	3
M-38-600	CAT	1	6.1	7.75	6	0.75	4	0.5	4
M-38-800	CAT	2	8.1	11	9.88	0.5	8	0.5	6
M-38-1000	CAT	2	10.1	13.5	12.44	0.5	12	0.5	9
M-38-1000-3516ULB	CAT	2	10.13	14	12.6	0.56	12	0.5	10
M-38-1200	CAT	2	12.1	16	14.8	0.5	12	0.5	12
M-38-1400	CAT	2	14.2	18.5	16.93	0.63	12	0.5	15
M-38-1800	CAT	2	18.12	22.51	20.88	0.62	16	0.5	19
M-39-600	MTU/DET	2	6.06	9.5	8.19	0.44	6	0.5	5
M-39-800	MTU/DET	2	8.1	11	9.88	0.5	8	0.5	6
M-39-1000	MTU/DET	2	10	13	11.88	0.63	8	0.5	7
M-40-600	CUM	2	6.1	8	7.19	0.44	8	0.5	3

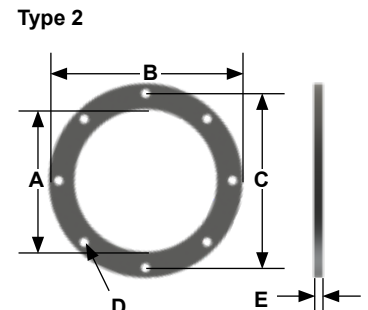
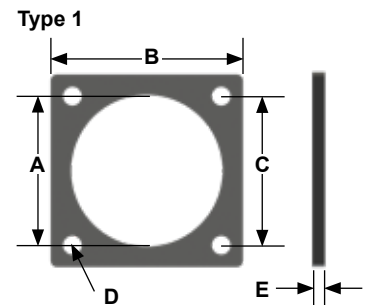

- All dimensions are in inches. All weights are in pounds. Weights are approximate.
- Other sizes available, call for details.
- † 37-450 used on the following engines: Airesearch TV801, T1885, T18A40, All Schwitzer, DDA Turbo, and Cummins K.



M-41 FLANGES

ANSI Pattern Flanges

ANSI Pattern Steel Plate, Carbon Steel								
Part Number	Pipe/Tube	A (ID)	B (OD)	C (BC)	D (DIA)	Holes	E (THK)	WT
M-41-T-200	Tube	2.00	6.0	4.75	0.75	4	0.5	3.2
M-41-P-200	Pipe	2.38	6.0	4.75	0.75	4	0.5	3
M-41-T-250	Tube	2.50	7.0	5.50	0.75	4	0.5	4.2
M-41-P-250	Pipe	2.88	7.0	5.50	0.75	4	0.5	4
M-41-T-300	Tube	3.00	7.5	6.00	0.75	4	0.5	4.7
M-41-P-300	Pipe	3.50	7.5	6.00	0.75	4	0.5	5.2
M-41-T-350	Tube	3.50	8.5	7.00	0.75	8	0.5	5.5
M-41-P-350	Pipe	4.00	8.5	7.00	0.75	8	0.5	5.5
M-41-400	Tube	4.00	9.0	7.50	0.75	8	0.5	7
M-41-450	Pipe	4.50	9.0	7.50	0.75	8	0.5	6
M-41-500	Tube	5.00	10.0	8.50	0.88	8	0.5	7.5
M-41-556	Pipe	5.56	10.0	8.50	0.88	8	0.5	7
M-41-600	Tube	6.00	11.0	9.50	0.88	8	0.5	8.5
M-41-663	Pipe	6.63	11.0	9.50	0.88	8	0.5	7.5
M-41-800	Tube	8.00	13.5	11.75	0.88	8	0.5	12.5
M-41-863	Pipe	8.63	13.5	11.75	0.88	8	0.5	11
M-41-1000	Tube	10.00	16.0	14.25	1.00	12	0.5	18
M-41-1075	Pipe	10.75	16.0	14.25	1.00	12	0.5	17
M-41-1200	Tube	12.00	19.0	17.00	1.00	12	0.5	21
M-41-1275	Pipe	12.75	19.0	17.00	1.00	12	0.5	20
M-41-1400	Tube	14.10	21.0	18.75	1.13	12	0.5	24
M-41-1600	Tube	16.10	23.5	21.25	1.13	16	0.5	28
M-41-1800	Tube	18.10	25.0	22.75	1.25	16	0.5	30
M-41-2000	Tube	20.10	27.5	25.00	1.25	20	0.5	34
M-41-2200	Tube	22.10	29.5	27.25	1.38	20	0.5	36
M-41-2400	Tube	24.10	32.0	29.50	1.38	20	0.625	38
M-41-2600	Tube	26.10	34.3	31.75	1.38	24	0.625	43
M-41-2800	Tube	28.10	36.5	34.00	1.38	28	0.625	49
M-41-3000	Tube	30.10	38.8	36.00	1.38	28	0.625	55
M-41-3600	Tube	36.00	46.0	42.8	1.6	32	0.625	80

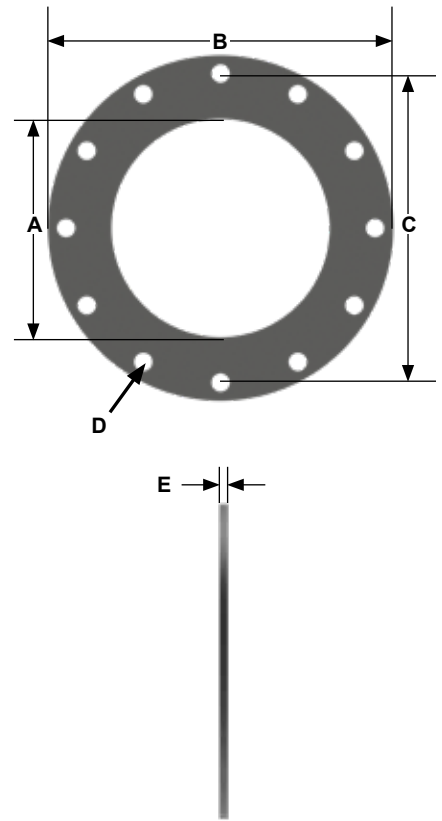

M-45 to M-46 FLANGES

Threaded Flat Face and Reducing / Increasing Flanges

ANSI Threaded Flat Face

Part Number	Thread Size	BC Diameter
M-45-150	1.5	3.9
M-45-200	2	4.8
M-45-250	2.5	5.5
M-45-300	3	6.0
M-45-350	3.5	7.0
M-45-400	4	7.5
M-45-500	5	8.5
M-45-600	6	9.5
M-45-800	8	11.8

NPT Standard Pipe Threads.

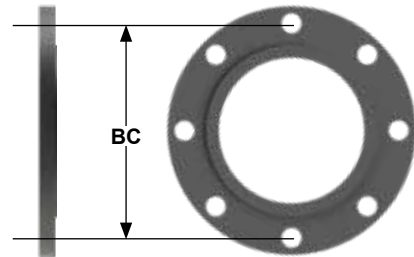

ANSI Reducing / Increasing

Part Number Pipe	Part Number Tube	Reducing Size	IPS Size	BC Diameter	WT
M-46-P-430	M-46-T-430	4 x 3	3.0	7.50	8
M-46-P-435	M-46-T-435	4 x 3.5	3.5	7.50	8
M-46-P-535	M-46-T-535	5 x 3.5	3.5	8.50	9
M-46-P-540	M-46-T-540	5 x 4	4.0	8.50	9
M-46-P-640	M-46-T-640	6 x 4	4.0	9.50	11
M-46-P-650	M-46-T-650	6 x 5	5.0	9.50	10
M-46-P-840	M-46-T-840	8 x 6	4.0	11.75	18
M-46-P-850	M-46-T-850	8 x 5	5.0	11.75	17
M-46-P-860	M-46-T-860	8 x 6	6.0	11.75	16
M-46-P-1060	M-46-T-1060	10 x 6	6.0	14.25	23
M-46-P-1080	M-46-T-1080	10 x 8	8.0	14.25	19
M-46-P-1280	M-46-T-1280	12 x 8	8.0	17.00	32
M-46-P-1210	M-46-T-1210	12 x 10	10.0	17.00	28
M-46-P-1480	M-46-T-1480	14 x 8	8.0	18.75	39
M-46-P-1410	M-46-T-1410	14 x 10	10.0	18.75	36
M-46-P-1412	M-46-T-1412	14 x 12	12.0	18.75	31

Flanges (.50") thick carbon steel plate.

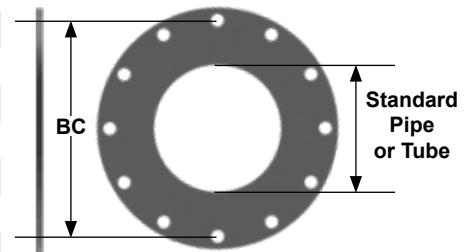

- All dimensions are in inches. All weights are in pounds. Weights are approximate.
- Other sizes available, call for details.
- Available in stainless steel.