

# FPC-FPCE INTERNAL CENTER PANEL ABSORPTIVE DESIGN

## 20 to 25 dBA Noise Reduction



### Silencer Specification



### OVERVIEW

Use for a medium to high degree of high frequency noise attenuation. FPC is for intake service and the FPCE for exhaust service.

Typical Applications: Internal combustion engine intakes and exhaust, compressor intakes or fan intakes and discharges

### FEATURES

- Advanced acoustical design
- Heavy duty, all welded construction and long service life
- Easily installed in any position
- Prime coated exterior finish

### OPTIONS / ACCESSORIES

- Horizontal or vertical support arrangements
- Special paint
- Stainless steel construction
- Complete range of exhaust accessories

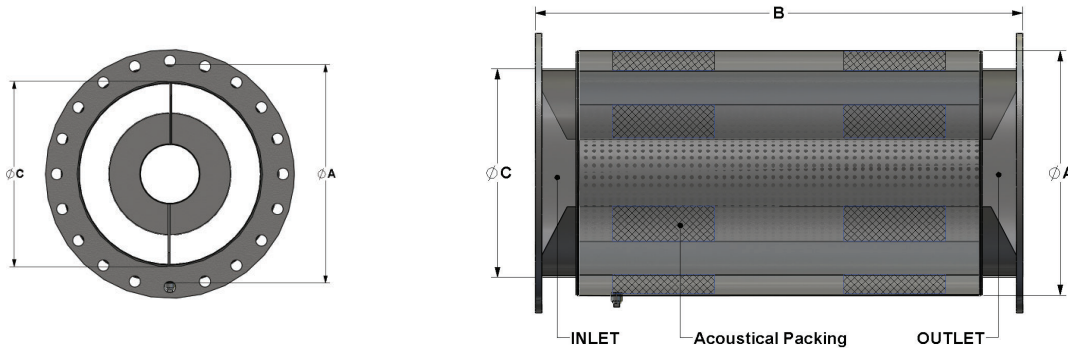
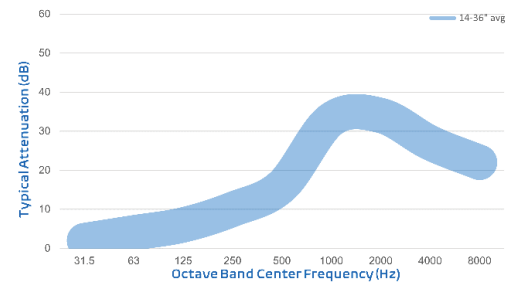

### PRODUCT SPECS

Model-Size	Model-Size	C (size)	A (dia)	B (OAL)	Est Wt
FPC-14	FPCE-14	14	18	35	200
FPC-16	FPCE-16	16	20	39	240
FPC-18	FPCE-18	18	22	44	300
FPC-20	FPCE-20	20	24	48	360
FPC-22	FPCE-22	22	26	52	430
FPC-24	FPCE-24	24	28	56	590
FPC-26	FPCE-26	26	30.375	60	700
FPC-28	FPCE-28	28	32.5	64	800
FPC-30	FPCE-30	30	35.375	68	900
FPC-32	FPCE-32	32	37	72	1200
FPC-34	FPCE-34	34	39.5	76	1330
FPC-36	FPCE-36	36	42	80	1490
FPS-30	FPSE-30	30	49	121	1900

- All dimensions are in inches. All weights are in pounds. Weights are approximate.
- Listed sound data is based on typical performance and should not be considered absolute.
- See nomenclature guide for additional information on part number creation.