

Silencer Specification



OVERVIEW

Designed for a high degree of high frequency noise attenuation. FPS is for intake service and the FPSE for exhaust service.

Typical Applications: Internal combustion engine intakes and exhaust, compressor intakes or fan intakes and discharges

FEATURES

- Advanced acoustical design
- Heavy duty, all welded construction and long service life
- Easily installed in any position
- Prime coated exterior finish

OPTIONS / ACCESSORIES

- Horizontal or vertical support arrangements
- Special paint
- Stainless steel construction
- Complete range of exhaust accessories

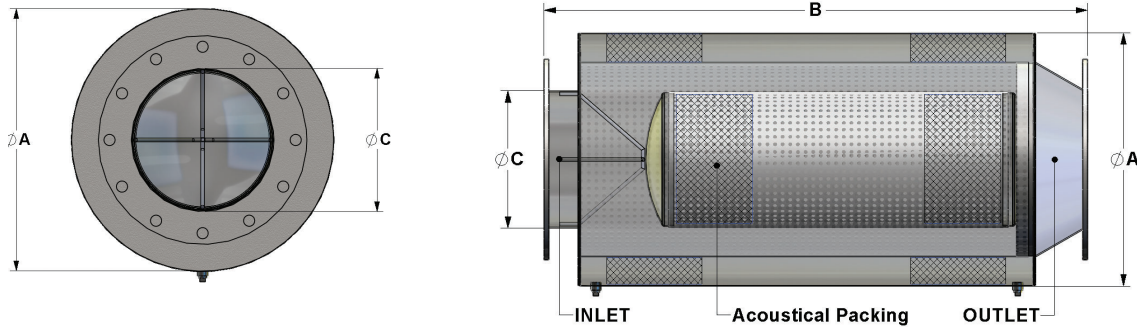
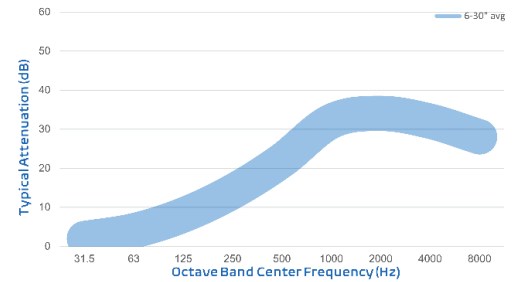

PRODUCT SPECS

Model-Size	Model-Size	C (size)	A (dia)	B (OAL)	Est Wt
FPS-6	FPSE-6	6	14.625	27	75
FPS-8	FPSE-8	8	18	35	130
FPS-10	FPSE-10	10	20.75	44	190
FPS-12	FPSE-12	12	23.375	51	270
FPS-14	FPSE-14	14	26.375	57	370
FPS-16	FPSE-16	16	29.125	66	490
FPS-18	FPSE-18	18	32.125	71	565
FPS-20	FPSE-20	20	34.875	83	820
FPS-22	FPSE-22	22	37.75	89	1000
FPS-24	FPSE-24	24	40.5	98	1280
FPS-26	FPSE-26	26	43.375	106	1530
FPS-28	FPSE-28	28	46.25	111	1700
FPS-30	FPSE-30	30	49	121	1900

- All dimensions are in inches. All weights are in pounds. Weights are approximate.
- Listed sound data is based on typical performance and should not be considered absolute.
- See nomenclature guide for additional information on part number creation.