

# RESIDENTIAL SPARK ARRESTING LOW PROFILE CHAMBER

## 19 to 25 dBA Noise Reduction

### MDSA22 OVERVIEW

The MDSA22 is engineered to provide a spark arresting residential grade attenuation while minimizing space usage where fire hazards exist. Centrifugal force separates solids from the exhaust gas stream in an easily accessible cleanout. It is an excellent choice for packaged power and process skids where space is a premium. Dual inlets and other custom designs can be easily incorporated. Suitable for use where background noise is extremely low, such as residential or industrial locations away from busy streets.

Typical Applications: Internal combustion engines, process skids, genset enclosures, as well as marine engines.

### FEATURES

- Heavy duty, welded construction
- Unpacked/Non-insulated design
- Low surface temperature design
- ANSI drilled 125/150 lb. flanges on inlet and outlet
- High-temperature, prime coated black finish
- Lift lugs

### OPTIONS / ACCESSORIES

- Low surface temperature design
- Stainless steel construction: 304 or 316
- Custom inlet/outlet size, location and multiple orientations available
- Support brackets
- Special paints and finishes available
- 1" to 2" internal insulation available
- Complete range of exhaust accessories

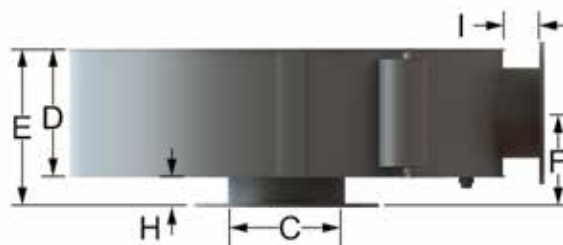
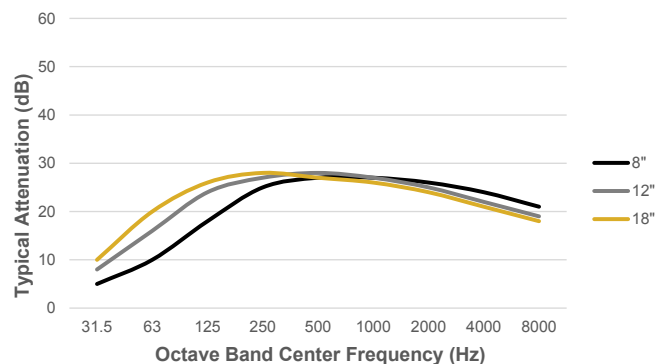
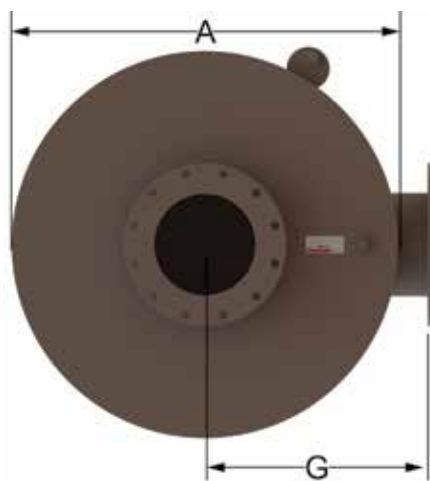

MDSA22										
Part No.*	Size / ØC	ØA	D	E	F	G	H	I	Est Wt	
MDSA22-4	4	22	7	11	7.5	15	4	4	105	
MDSA22-5	5	24	8	12	8	16	4	4	121	
MDSA22-6	6	28	8.5	12.5	8.25	18	4	4	149	
MDSA22-8	8	33	12	16	10	20.5	4	4	239	
MDSA22-10	10	41	13	17	10.5	24.5	4	4	335	
MDSA22-12	12	45	17	21	12.5	26.5	4	4	475	
MDSA22-14	14	52	18	22	13	30	4	4	550	
MDSA22-16	16	59	21	23	14.5	33.5	4	4	728	
MDSA22-18	18	65	23	27	15.5	36.5	4	4	838	

- All dimensions are in inches. All weights are in pounds. Weights are approximate.
- A minimum 3" gap is recommended between the silencer and enclosure roof.
- Listed sound data is based on typical performance and should not be considered absolute.
- \*See [nomenclature guide](#) for additional information on part number creation.



# CRITICAL SPARK ARRESTING LOW PROFILE CHAMBER

## 22 to 28 dBA Noise Reduction

### MDSA32 OVERVIEW

The MDSA32 is engineered to provide a spark arresting critical grade attenuation while minimizing space usage fire hazards exist. Centrifugal force separates solids from the exhaust gas stream in an easily accessible cleanout. It is an excellent choice for packaged power and process skids where space is a premium. Dual inlets and other custom designs can be easily incorporated. Design not only reduces surface temperature, but also radiated noise.

Typical Applications: Internal combustion engines, process skids, genset enclosures, as well as marine engines.

### FEATURES

- Heavy duty, welded construction
- Low surface temperature design
- ANSI drilled 125/150 lb. flanges on inlet and outlet
- High-temperature, prime coated black finish
- 2" thick internal insulation within double wall construction
- Lift lugs

### OPTIONS / ACCESSORIES

- Stainless steel construction: 304 or 316
- Custom inlet/outlet size, location and multiple orientations available
- Support brackets
- Special paints and finishes available
- 1" internal insulation available
- Complete range of exhaust accessories

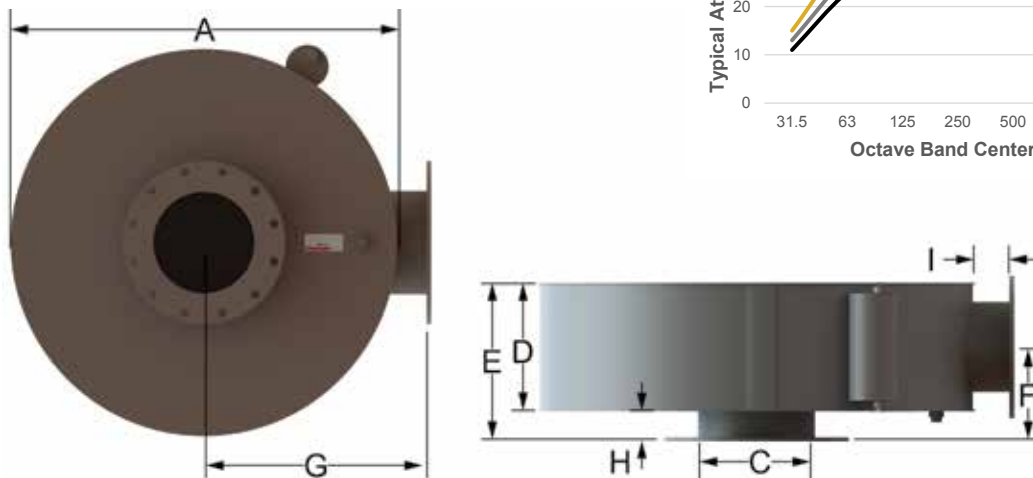
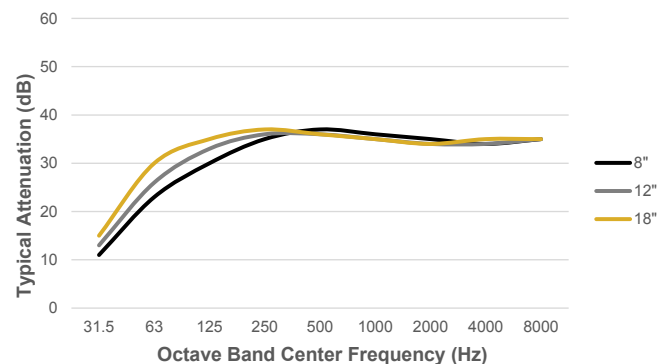

MDSA32									
Part No.*	Size / ØC	ØA	D	E	F	G	H	I	Est Wt
MDSA32-4	4	28	9	13	8.5	18	4	4	130
MDSA32-5	5	29	11	15	9.5	18.5	4	4	150
MDSA32-6	6	33	12	16	10	20.5	4	4	192
MDSA32-8	8	45	14	18	11	26.5	4	4	341
MDSA32-10	10	52	16	20	12	30	4	4	561
MDSA32-12	12	62	18	22	13	35	4	4	816
MDSA32-14	14	64	23	28	16.5	37	5	5	950
MDSA32-16	16	74	25	30	17.5	42	5	5	1388
MDSA32-18	18	84	27	32	18.5	47	5	5	1856
MDSA32-20	20	92	28	33	19	51	5	5	2186

- All dimensions are in inches. All weights are in pounds. Weights are approximate.
- A minimum 3" gap is recommended between the silencer and enclosure roof.
- Listed sound data is based on typical performance and should not be considered absolute.
- \*See [nomenclature guide](#) for additional information on part number creation.



# SUPER CRITICAL SPARK ARRESTING LOW PROFILE CHAMBER

## 30 to 37 dBA Noise Reduction

### MDSA42 OVERVIEW

The MDSA42 is engineered to provide a spark arresting super critical grade attenuation while minimizing space usage where fire hazards exist. Centrifugal force separates solids from the exhaust gas stream in an easily accessible cleanout. It is an excellent choice for packaged power and process skids where space is a premium. Dual inlets and other custom designs can be easily incorporated. Design not only reduces surface temperature, but also radiated noise. Suitable for use where background noise is extremely low, such as residential or hospital locations away from busy streets.

Typical Applications: Internal combustion engines, process skids, genset enclosures, as well as marine engines.

### FEATURES

- Heavy duty, welded construction
- Low surface temperature design
- ANSI drilled 125/150 lb. flanges on inlet and outlet
- High-temperature, prime coated black finish
- 2" thick internal insulation within double wall construction
- Lift lugs

### OPTIONS / ACCESSORIES

- Stainless steel construction: 304 or 316
- Custom inlet/outlet size, location and multiple orientations available
- Support brackets
- Special paints and finishes available
- 1" internal insulation available
- Complete range of exhaust accessories

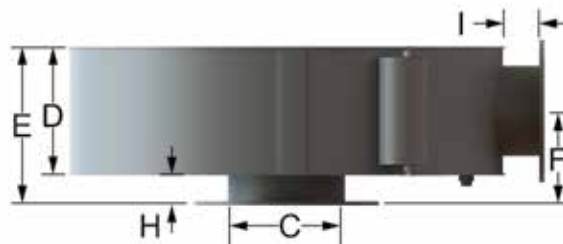
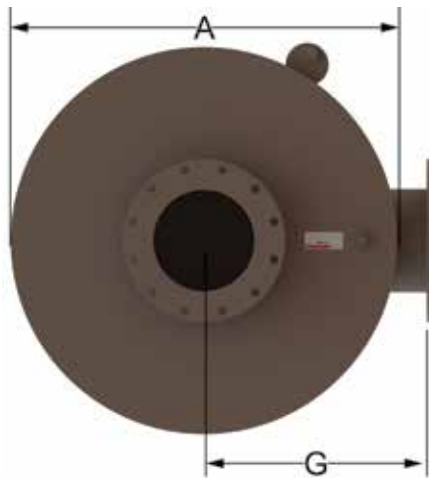
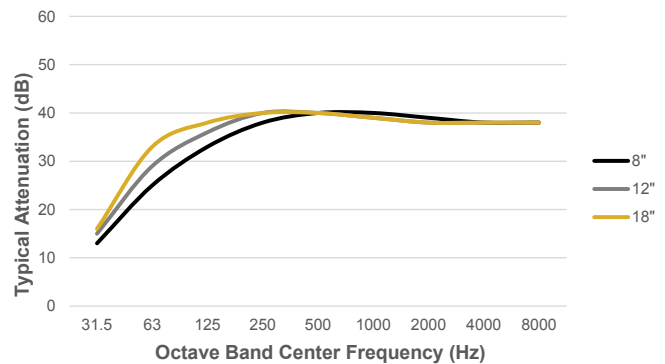

MDSA42										
Part No.*	Size / ØC	ØA	D	E	F	G	H	I	Est Wt	
MDSA42-4	4	32	10	14	9	20	4	4	165	
MDSA42-5	5	32	11	15	9.5	20	4	4	174	
MDSA42-6	6	38	12	16	10	23	4	4	238	
MDSA42-8	8	52	14	18	11	30	4	4	518	
MDSA42-10	10	59	16	20	12	33.5	4	4	701	
MDSA42-12	12	70	18	22	13	39	4	4	984	
MDSA42-14	14	70	24	29	17	40	5	5	1104	
MDSA42-16	16	75	28	33	19	42.5	5	5	1518	
MDSA42-18	18	86	30	35	20	48	5	5	2006	
MDSA42-20	20	94	32	37	21	52	5	5	2375	

- All dimensions are in inches. All weights are in pounds. Weights are approximate.
- A minimum 3" gap is recommended between the silencer and enclosure roof.
- Listed sound data is based on typical performance and should not be considered absolute.
- \*See [nomenclature guide](#) for additional information on part number creation.

